

TRANSFER DIAGNOSIS <ACTIVE TRAC 4WD II>

TRANSFER (ACTIVE TRAC 4WD II) DIAGNOSTIC TROUBLESHOOTING STRATEGY

M1231110800040

Use these steps to plan your diagnostic strategy. If you follow them carefully, you will find most transfer malfunctions.

1. Gather as much information as possible about the complaint from the customer.
2. Verify that the condition described by the customer exists.
3. Check the vehicle for any transfer Diagnostic Trouble Codes (DTCs).
4. If you can not verify the condition and there are no DTCs, the malfunction is intermittent. For information on how to cope with intermittent malfunctions, refer to GROUP 00, How to Use Troubleshooting/Inspection Service Points – How to Cope with Intermittent Malfunction P.00-6.
5. If there is a DTC, record the number of the code, then erase the code from memory using scan tool MB991502.
6. If a DTC is set again, go to Inspection Chart for Diagnostic Trouble Codes.
7. If a DTC is not set again, the malfunction is intermittent. For information on how to cope with intermittent malfunctions, refer to GROUP 00, How to Use Troubleshooting/Inspection Service Points – How to Cope with Intermittent Malfunction P.00-6.
8. After repairs are completed, confirm the malfunction has been eliminated.

TRANSFER DIAGNOSTIC TROUBLE CODE DIAGNOSIS

M1231110900047

CHECK CENTER DIFFERENTIAL LOCK INDICATOR LIGHT

The center differential lock indicator light flashes once per second if there is an abnormality in any of the items below which are related to the transfer system. Check for diagnostic trouble codes if the center differential lock indicator light is flashing once per second.

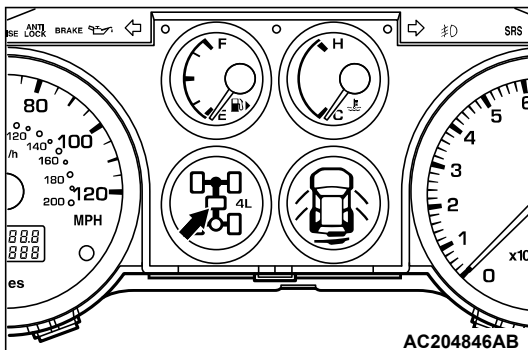

ON-BOARD DIAGNOSTICS

The transfer-ECU monitors its input/output signals (some signals all the time and others under specified conditions). When an irregular signal is initially monitored, the transfer-ECU decides that a malfunction has occurred and records the occurrence as a diagnostic trouble code. There are 21 diagnostic items. The diagnostic results can be read with a scan tool. Diagnostic trouble codes are kept in memory by direct battery feed. The codes are retained in memory even if the ignition switch is in the "LOCK" (OFF)

position. Diagnostic trouble codes will, however, be erased when a battery terminal or the transfer-ECU connector is disconnected. In addition, the diagnostic trouble code can also be erased by scan tool MUT-II (MB991502).

NOTE: If a sensor is disconnected when the ignition switch is in the "ON" position a diagnostic trouble code is stored in memory. In this case, erase the DTC using scan tool MB991502.

The 21 diagnostic items are displayed in numeric order.

HOW TO READ AND ERASE DIAGNOSTIC TROUBLE CODES**<When using the scan tool>****Required Special Tool:**

- MB991502: Scan Tool (MUT-II)

⚠ CAUTION

To prevent damage to scan tool MB991502, always turn the ignition switch to the "LOCK" (OFF) position before connecting or disconnecting scan tool MB991502.

NOTE: If the battery positive voltage is low, diagnostic trouble codes will not be output. Check the battery if the scan tool MB991502 can not display.

NOTE: If the battery is disconnected or if the transfer-ECU connector is disconnected, the diagnostic trouble codes will be erased. Do not disconnect the battery or transfer-ECU before the diagnostic trouble codes have been read.

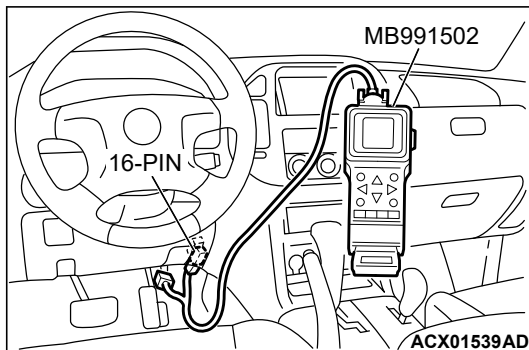

1. Connect scan tool MB991502 to the data link connector.
2. Turn the ignition switch to the "ON" position.
3. Record the diagnostic trouble codes (DTCs) for transfer.
4. Refer to P.23Ab-47, Diagnostic Trouble Code Chart.
5. Turn the ignition switch to the "LOCK" (OFF) and then back to "ON" again.
6. Erase the diagnostic trouble code by selecting DTC erase from SPECIAL MENU screen, using scan tool MB991502.
7. Check for diagnostic trouble codes. Confirm the scan tool displays "normal."
8. Turn the ignition switch to the "LOCK" (OFF) position.
9. Disconnect scan tool MB991502.

<When using the differential lock indicator light>**Required Special Tool:**

- MB991529: Diagnostic Trouble Code Check Harness

1. Use special tool MB991529 to ground terminal number 1 of the data link connector.
2. Turn on the ignition switch to the "ON" position.

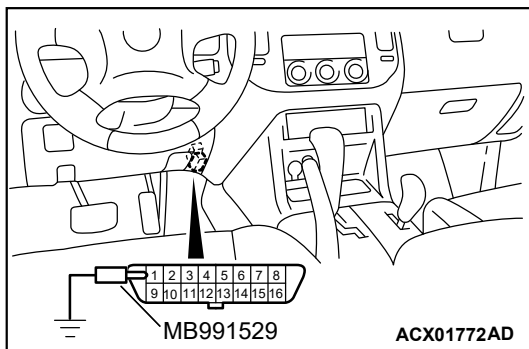

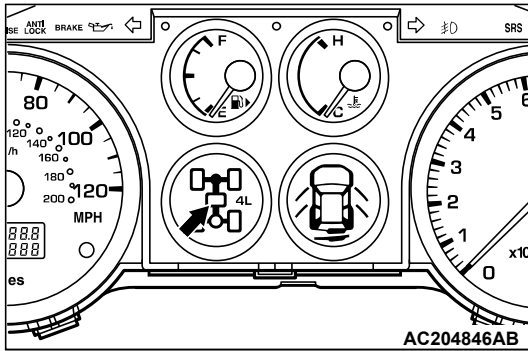

3. Read the diagnostic trouble codes by counting center differential lock indicator light flashes.
4. Refer to P.23Ab-47, Diagnostic Trouble Codes Chart.
5. Erase the diagnostic trouble codes by the following procedure.
 - (1) Turn the ignition switch to the "LOCK" (OFF) position.
 - (2) Disconnect the negative battery cable for 10 seconds or more. Reconnect the cable.
 - (3) Turn the ignition switch to the "ON" position. Read the diagnostic trouble code output and check that no diagnostic trouble code is output.
 - (4) Start the engine and let it run until the engine has warmed up. Run it at idle for approximately 10 minutes or longer. The engine control module must build up the adaptive memory for smooth idle and good performance.

UNDERSTANDING THE CENTER DIFFERENTIAL LOCK INDICATOR LIGHT FLASHES

EXAMPLE OF FLASHING WHEN A DIAGNOSTIC TROUBLE CODE IS SET	FLASHING WHEN NORMAL
<p>FOR DIAGNOSTIC TROUBLE CODE No.23</p> <p style="text-align: center;">ACX01947AB</p>	<p style="text-align: center;">ACX01929AB</p>

NOTE: Other diagnostic trouble codes also are output by the flashing of the center differential lock indicator light corresponding to the same code numbers as the scan tool displays.

**INSPECTION USING SCAN TOOL MB991502,
DATA LIST**

Required Special Tool:

- MB991502: Scan Tool (MUT-II)

⚠ CAUTION

To prevent damage to scan tool MB991502, always turn the ignition switch to the "LOCK" (OFF) position before connecting or disconnecting scan tool MB991502.

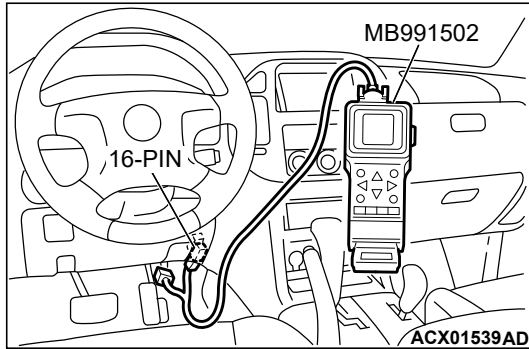

1. Connect scan tool MB991502 to data link connector.
2. Turn the ignition switch to the "ON" position.
3. Carry out inspection by means of the Data List function. If there is an abnormality, check and repair the chassis harnesses and components. Refer to P.23Ab-49, Data List Reference Table.
4. Re-check using scan tool MB991502 and confirm that the abnormal input and output have returned to normal because as a result of the repairs.
5. Check for and inspect any diagnostic trouble codes (DTCs) that may have surfaced from testing. Erase the diagnostic trouble codes (DTCs) when finished checking.
6. Turn the ignition switch to the "LOCK" (OFF) position.
7. Disconnect scan tool MB991502 from the data link connector.
8. Start the engine again and do a test drive to confirm that the problem is eliminated.

FAIL-SAFE/BACKUP FUNCTIONS

When malfunctions of the main sensors or actuators are detected by the transfer-ECU, the transfer is controlled by pre-set control logic to maintain safe conditions for driving.

The following table shows how the fail-safe/backup function affects vehicle driveability and operation.

M1231111000047

MALFUNCTIONING ITEM	JUDGMENT CONDITION	CONTROL CONTENTS DURING MALFUNCTION
Power supply voltage	Power supply voltage is 9.5 V and less.	Control start prohibited
	Power supply voltage is 18 V and over.	Control stop
Main relay (inside of ECU)	Voltage at relay OFF is 6 V and over, or voltage at relay ON is 6 V and less.	Control stop
Accelerator pedal position sensor (APP)	APP voltage at idle condition is less than 0.2 V.	Vehicle speed limitation
Front propeller shaft speed sensor 1	Input signal from front propeller shaft speed sensor is unstable during low and medium speed driving. (When malfunction is detected during 2WD → 4WD shifting)	Control start prohibited
Front propeller shaft speed sensor 2	Input signal from front propeller shaft speed sensor is unstable at freewheel engage switch ON condition. (When malfunction is detected at 4WD condition)	Control start prohibited
Rear propeller shaft speed sensor 1	Input signal from rear propeller shaft speed sensor is unstable when APP voltage is 1.5 V and over. (When malfunction is detected at 2WD and 4WD conditions)	Control start prohibited

MALFUNCTIONING ITEM	JUDGMENT CONDITION	CONTROL CONTENTS DURING MALFUNCTION
Rear propeller shaft speed sensor 2	Input signal from rear propeller shaft speed sensor is unstable when freewheel engage switch is ON condition. (When malfunction is detected at 4WD condition)	Control start prohibited
Stoplight switch	Stoplight switch ON was detected for 15 minutes at vehicle speed of 15 km/h and over.	Control continued
Transfer shift lever switch	Input signal from transfer shift lever switch is unstable.	Control start prohibited
Transfer position switch 1	Shifting of transfer has not been completed during driving.	Control prohibited
Transfer position switch 2	Input signals from detection switches are unstable.	Control prohibited
Freewheel engage solenoid valve	Energizing condition to solenoid valve and ECU terminal voltage do not accord.	Control start prohibited
Freewheel engage switch	Energizing condition to solenoid valve and freewheel engage switch condition do not accord.	Control prohibited
Shift actuator abnormality	ECU terminal voltage is more than main relay voltage (90% of specified voltage) or lower than main relay voltage (10% of specified voltage).	Control stop
Shift actuator short-circuited	Actual value of actuator current is more than target value +1A.	Control stop
Shift actuator open-circuited	Main relay voltage is 6V and over or actual value of actuator current is less than 0.1 A.	Control stop
Shift actuator overload	Accumulation time to drive actuator exceeds 5 minutes.	Control stop
Dissimilar tire diameter	Speed difference between front wheel and rear wheel at 4WD condition is larger than set value.	Vehicle speed limitation
M-ASTC-ECU malfunction	Open circuit in all signal lies with the M-ASTC-ECU	Control continued
Transfer-ECU malfunction	Malfunction of ECU was detected.	Control stop

DIAGNOSTIC TROUBLE CODE CHART

M1231111100055

CODE	DIAGNOSIS ITEM	REFERENCE PAGE
11	Power supply voltage system	Low voltage
12		Over voltage
13	Main relay system (inside of ECU)	Relay malfunction
21	Accelerator pedal position sensor (APP) system	Open-circuit/sensor malfunction

CODE	DIAGNOSIS ITEM		REFERENCE PAGE
22	Front propeller shaft speed sensor system	Open-circuit/short-circuit/sensor malfunction	P.23Ac-275
23			P.23Ac-275
24	Rear propeller shaft speed sensor system	Open-circuit/short-circuit/sensor malfunction	P.23Ac-287
25			P.23Ac-287
26	Stoptlight switch system	Open-circuit/short-circuit/lamp failure/switch failure	P.23Ac-299
31	Transfer shift lever switch system	Open-circuit/short-circuit/switch failure	P.23Ac-307
32	Transfer position switch system	Transfer shift mechanism malfunction/actuator malfunction	P.23Ac-315
33	Transfer position switch system	Open-circuit/short-circuit/switch failure	P.23Ac-315
34	Free-wheel engage solenoid valve system	Open-circuit/short-circuit/solenoid valve malfunction	P.23Ac-326
35	Free-wheel engage switch system	Open-circuit/short-circuit/switch failure	P.23Ac-338
41	Shift actuator system (short-circuit, open-circuit)	Open-circuit/short-circuit/actuator malfunction/ECU malfunction	P.23Ac-349
42	Shift actuator system (short-circuit)	Short-circuit/actuator malfunction/ECU malfunction	P.23Ac-355
43	Shift actuator system (open-circuit)	Open-circuit/actuator malfunction/ECU malfunction	P.23Ac-355
44	Shift actuator system (Overload)	Transfer shift mechanism malfunction/actuator malfunction	P.23Ac-361
45	Dissimilar tire diameter	Incorrect tire pressure/dissimilar tire size	P.23Ac-367
51	Transfer-ECU malfunction		Replace the transfer-ECU
61	M-ASTC-ECU malfunction	Open-circuit/short-circuit/ECU malfunction	P.23Ac-368